



## Crane Merchant Ambient MEDIA2 Model 186/187

# ELEVATE THE CONSUMER EXPERIENCE LIKE NEVER BEFORE

## INTRODUCING THE REDESIGNED MERCHANT AMBIENT

Enabled for suggestive selling and digital advertising, the MEDIA2 screen on the CPI Merchant Ambient refrigerated vending machine lets you engage with consumers like never before. Merchant Ambient delivers:

### Faster Performance

The unit combines unparalleled product delivery speed, reliability, and on-screen responsiveness.

### Higher Engagement

A larger, 9-inch color touchscreen with full-motion video attracts consumers.

### Increased Sales

Suggestive selling and digital advertising drives impulse buys and add-on sales.

## Increase your revenue potential with Merchant Ambient



# THE FUTURE OF VENDING IS HERE

## CONSUMERS ENJOY THE EXPERIENCE

### Visual Display

Peak consumer interest with a larger, 9-inch color touchscreen and full-motion video.

### Suggestive Selling

Entice consumers with new products, slow movers, and complimentary selections.

### Shopping Cart

Enable consumers to make multi-product purchases from a single transaction.

### Nutritional Information

Inform consumers with a large display of easy-to-read nutrition facts.



## CUSTOMIZE YOUR END LOCATION

Graphics that connect with customers and drive sales

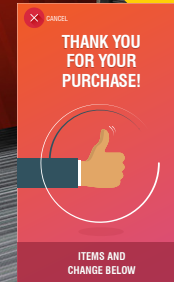

Color Display

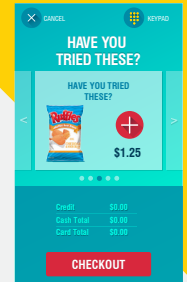

Suggestive Selling

## OPERATORS REAP THE REWARDS

### Screen Performance

Improve the user experience with a more responsive screen that boots up in less than a minute.

### Digital Advertising

Boost purchases and build brand loyalty with display advertising and interactive promotions throughout the purchase cycle.

### Low Operating Costs

Extremely efficient refrigeration system and highly insulated cabinet construction ensures low operating costs.

### Incredible Variety

Increase sales and consumer satisfaction by providing the best product selection in the industry.

### Integrated Cashless Payment

Capture every sale seamlessly with a built-in, intuitive cashless payment solution.

### Remote Management

Manage machines in the cloud with Simplifi Connect Plus to update pricing, and access planograms.

### Energy Efficient

Meet the latest Energy Star standards with a green, environmentally friendly refrigerant system.

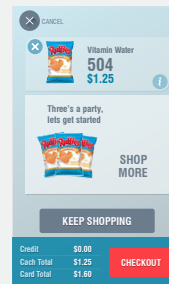

Shopping Cart

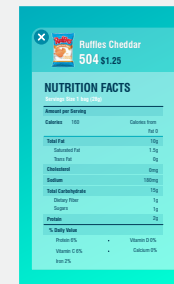

Nutritional Info

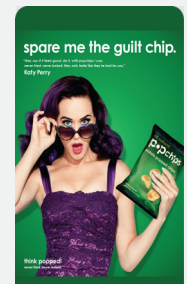

Digital Advertising

### MERCHANT AMBIENT MEDIA2 SPECIFICATIONS

Model	186 4-Wide	187 6-Wide
Height	1829 mm	1829 mm
Width	838 mm	1118 mm
Depth	953 mm	953 mm
Weight	223.6 kg	284.4 kg
Electrical	220-240 VAC	220-240 VAC
	50 Hz	50 Hz
	6A*	6A*
Selection	38 - 48	58 - 72

Available certifications: UL, cUL, FCC, CE  
Green Environmentally Friendly Refrigeration System with 1/3 HP Compressor

Learn more about Merchant Ambient MEDIA2  
[www.cranems.eu](http://www.cranems.eu)

# STANDARD CONFIGURATIONS:

## MERCHANT 4 SNACK & CONFECTIONERY

11	15	13	11	Snack				
9	9	9	9	Snack				
11	15	13	11	Snack				
17	17	17	17	20	20	15	15	Confectionery
17	17	17	17	20	20	15	15	Confectionery
11	9	9	11	Snack				
17	20	20	15	Snack				

Snack 248  
Confectionery 276  
Total 524

## MERCHANT 6 SNACK & CONFECTIONERY

11	15	15	15	13	11	Snack						
9	9	9	9	9	9	Snack						
11	13	15	15	13	11	Snack						
17	17	17	17	20	20	20	20	15	15	15	15	Confectionery
17	17	17	17	20	20	20	20	15	15	15	15	Confectionery
11	9	9	13	13	11	Snack						
17	17	20	20	15	15	Snack						

Snack 380  
Confectionery 416  
Total 796

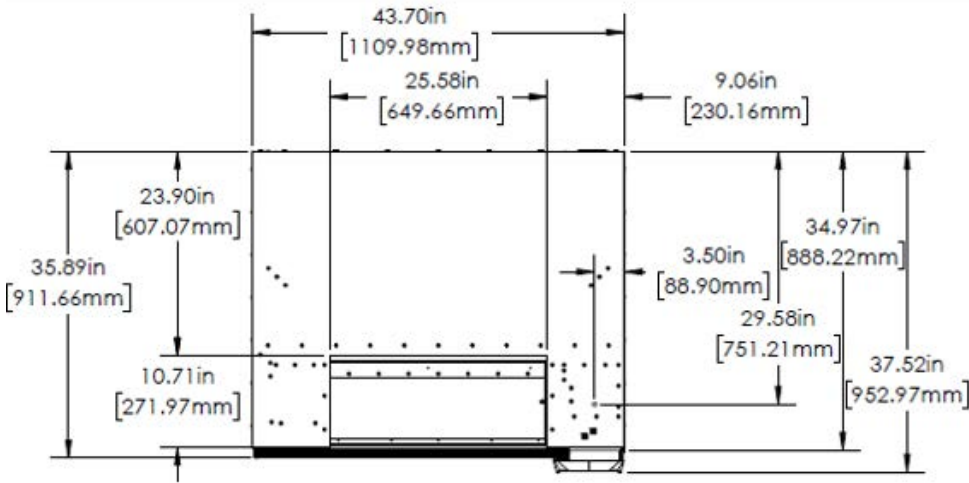

187

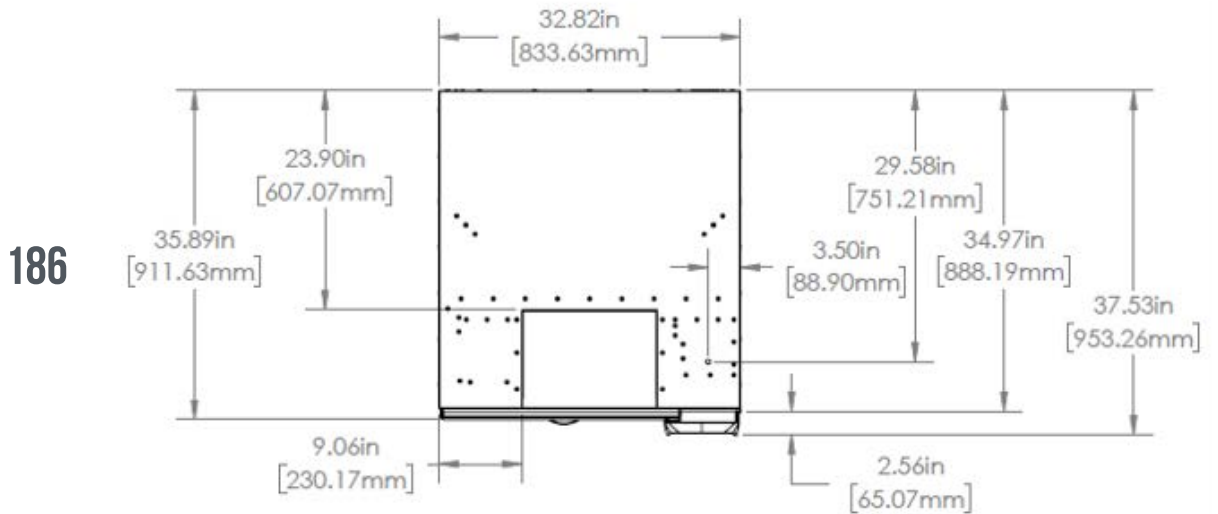

186



## EMEA APAC Headquarters

Pipsmore Park, Bumpers Farm Industrial Est. Chippenham, Wiltshire SN14 6NQ, UK  
t: +44 (0) 1249 444 807 | f: +44 (0) 1249 444 819 | sales@cranems.eu | www.cranems.eu